

Homework Assignment #5

Prob. 1 a) Obtain the transfer function of the three stage amplifier shown below. Note that all the amplifiers are inverting type. Identify the component conditions yielding a stable amplifier. i.e. Make sure all coefficients of the denominator are positive. Neglect effects of C_{pi} , $i = 1, 2, 3$.

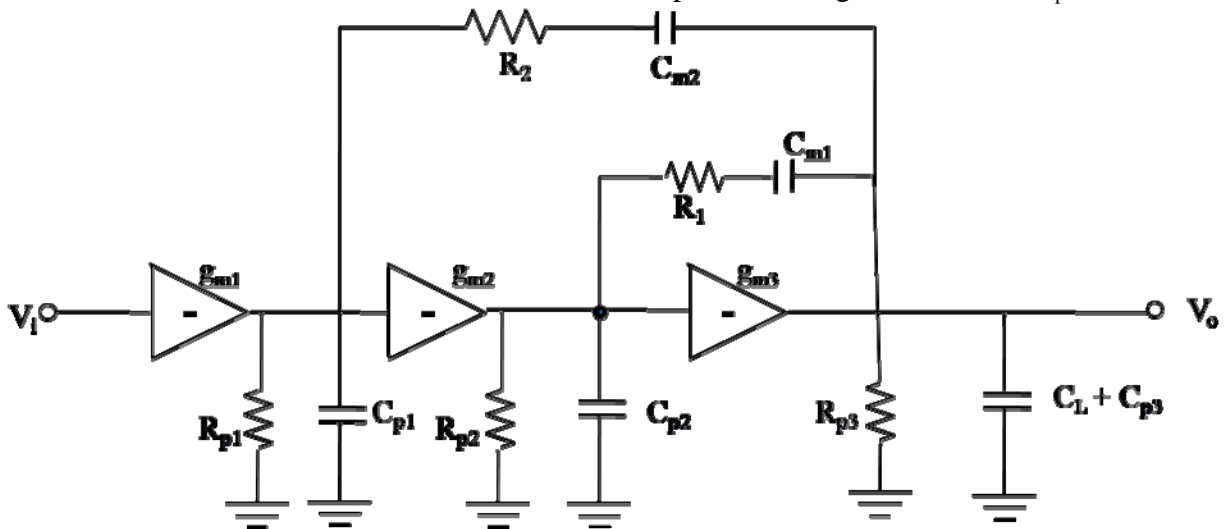

Extra Credit. Using this topology satisfy same specs in Prob. 1 HW 3 and design this amplifier.

Prob. 2. Design two folded cascoded amplifiers, one using conventional architecture and the second one using one of the topologies recently reported in the literature. Hint, we discussed several new topologies in our class notes. The specs to meet are the same as in Prob. 1 (HW3) but with 20% more power supply and at least 20dB more for DC gain. Provide a table comparing your two designs and discuss results.

Prob. 3. Modify one of the cascode amplifiers designed in Prob. 2, to improve linearity (THD) by at least 10dB using floating gate techniques. Discuss the trade-offs between area, power consumption and THD.

Reading Assignment: Chapter 10 (Razavi's Textbook) Stability and Frequency Compensation.