

Non-Linear Model for a source-degenerated OTA

Linear Transistor Model:

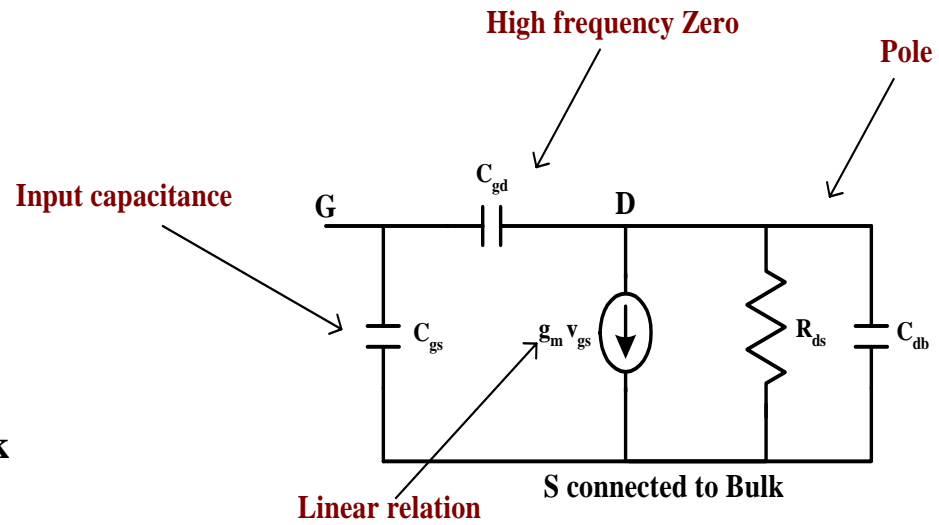

Linear OTA model:

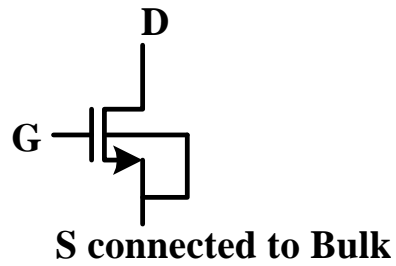
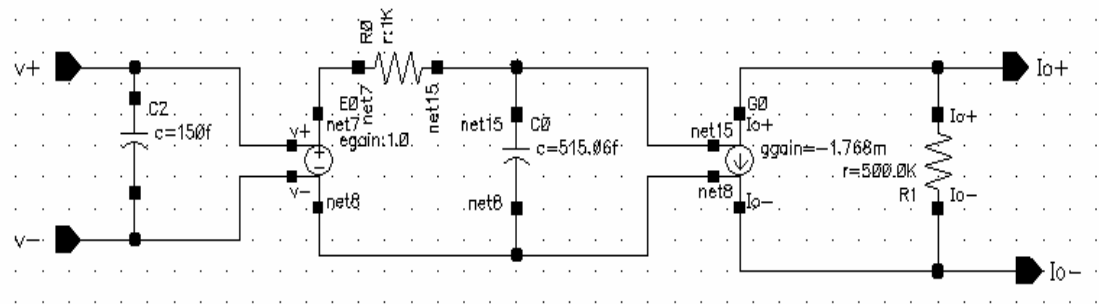
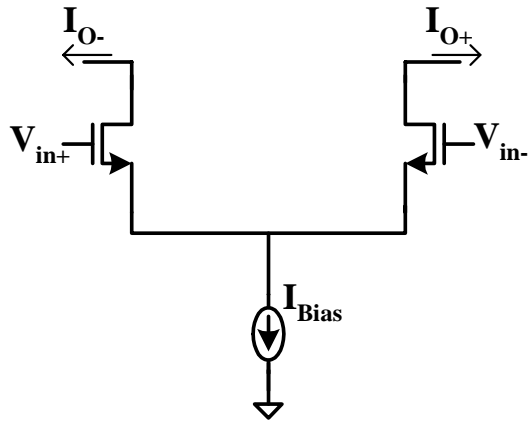

Non-Linear OTA model:

$$I_0 = I_1 - I_2, I_{DC} = I_1 + I_2$$

$$V_{GS1} - V_{GS2} = V_{in}^+ - V_{in}^- = v_d$$

$$I_0 = v_d \sqrt{\beta I_{DC}} \left(1 - \frac{\beta v_d^2}{4 I_{DC}} \right)^{1/2}$$

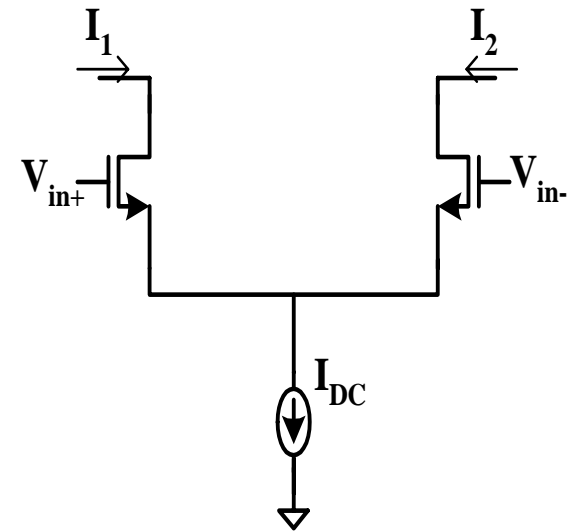

$$I_0 = \alpha_1 v_d + \alpha_3 v_d^3 + O(v_d^5)$$

How to Extract the Coefficients:

$$i_{out} = a_0 + a_1 v_d + a_2 v_d^2 + a_3 v_d^3$$

$$\text{At } v_d = 0, \quad i_{out} = a_0 \quad \frac{d}{dv_d} i_{out} = a_1 \quad \frac{d^2}{dv_d^2} i_{out} = 2a_2 \quad \frac{d^3}{dv_d^3} i_{out} = 6a_3$$

A source degenerated OTA as an example:

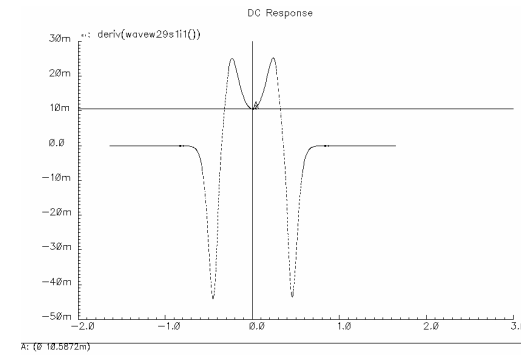
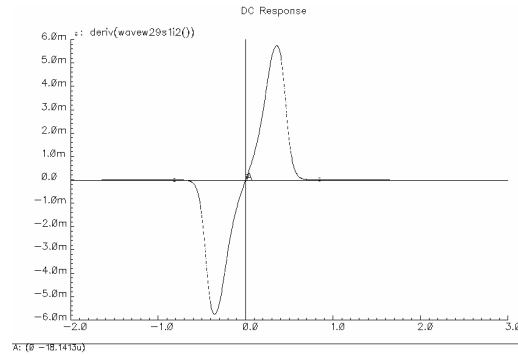
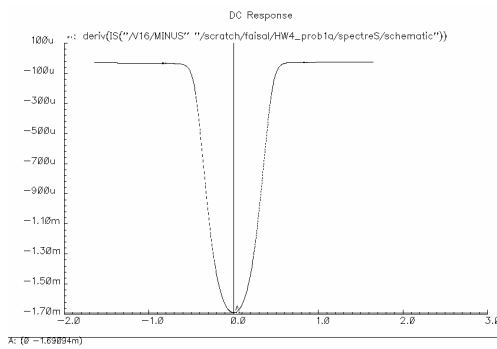
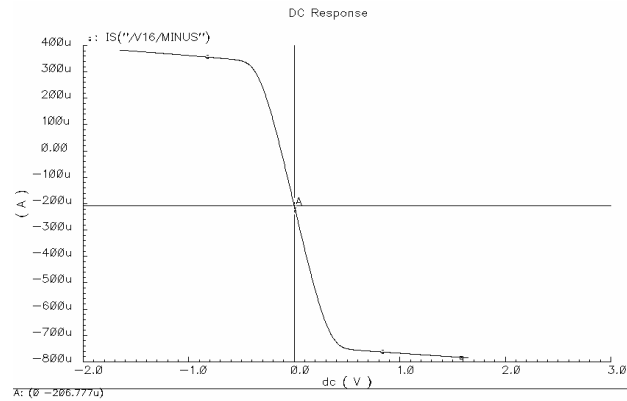
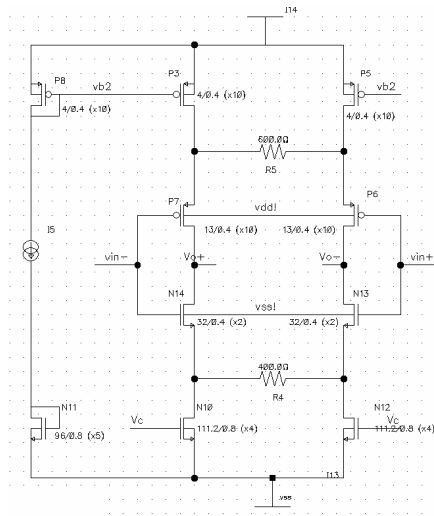

Coefficients:

```
File Help 15
Curve name map:
-----
Curve4 - deriv(deriv(deriv(IS("/V0/PLUS" "/scratch/faisal/HW4_prob1c/spectreS/schematic"))))
Curve3 - deriv(deriv(IS("/V0/PLUS" "/scratch/faisal/HW4_prob1c/spectreS/schematic")))
Curve2 - deriv(IS("/V0/PLUS" "/scratch/faisal/HW4_prob1c/spectreS/schematic"))
Curve1 - IS("/V0/PLUS")

Curve table:
-----
X value      Curve4      Curve3      Curve2      Curve1
M1 (anchor)  0  10.583547602m  -19.19775648u  -1.690939075m  -206.7681432u
```

Macromodel used:

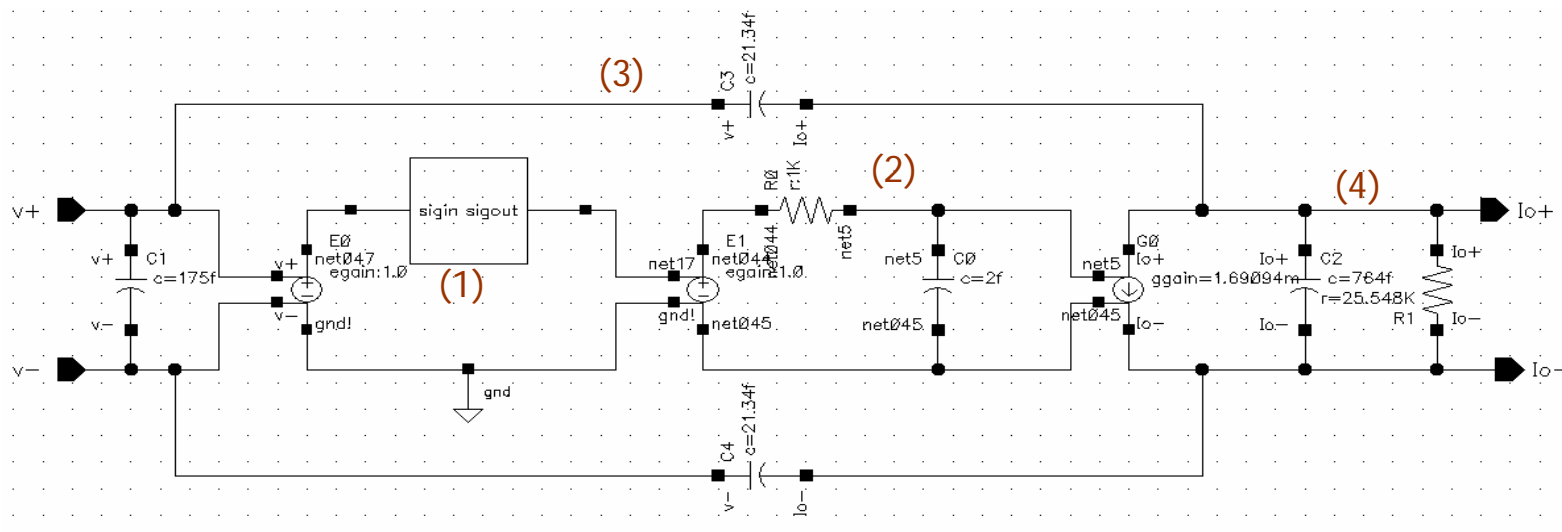

DC sweep of Macromodel:

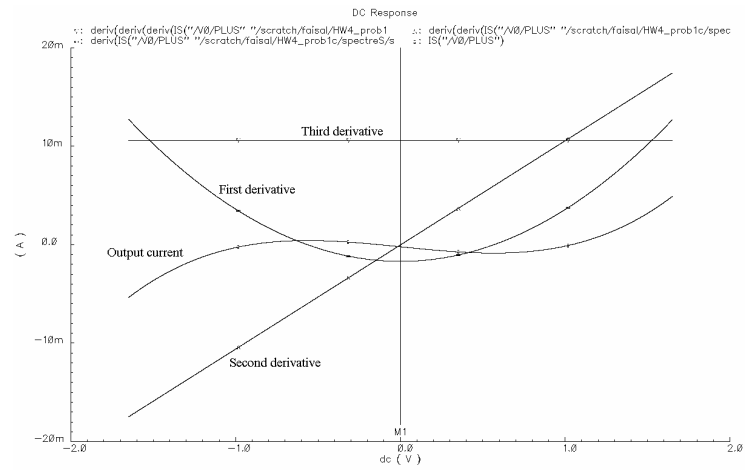

| | Transistor level | Macro-model | Percentage of error |
|------------------------------------|------------------|-------------|---------------------|
| a_0 (μA) | 206.777 | 206.768 | 4.3 m % |
| a_1 (mA/V) | 1.69094 | 1.69094 | 0 |
| a_2 ($\mu\text{A}/\text{V}^2$) | 9.07 | 9.5988 | 5.5 % |
| a_3 (mA/V ³) | -1.764 | -1.7639 | 5.66 m % |

AC response comparison:

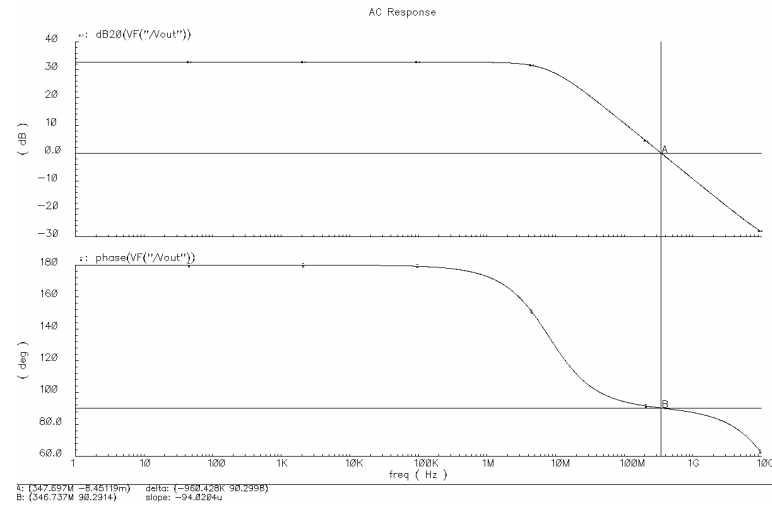
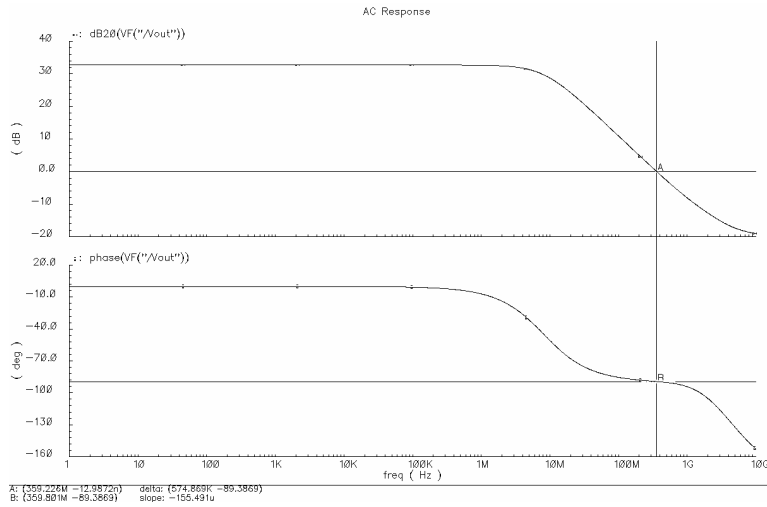

| | Transistor level | Macro-model | Percentage of error |
|--------------|--------------------|-------------------|---------------------|
| DC gain | 32.8 dB | 32.8 dB | 0 |
| ω_c | 359.226 MHz | 347.69 MHz | 3.3 % |
| Phase margin | 90.62 ^o | 89.7 ^o | 1.015 % |