

TWO-PORT NETWORKS INCLUDING SCATTERING PARAMETERS

- Conventional Two-Port Network Parameters.

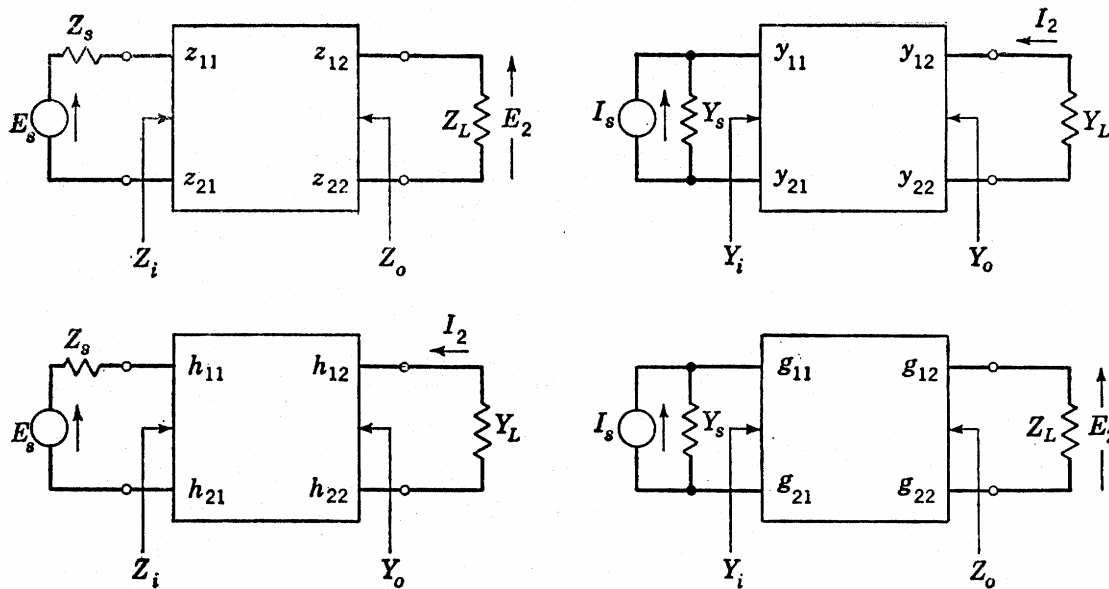

Several two ports, sources, and loads in different parameter systems with corresponding quantities indicated.

To demonstrate the expression forms independent of the particular two-port parameters, two derivations are carried out.

$$Z_{in} = \frac{E_1}{I_1}$$

$$E_1 = z_{11}I_1 + z_{12}I_2$$

$$\frac{E_1}{I_1} = z_{11} + \frac{I_2}{I_1} z_{12}$$

$$E_2 = -I_2 Z_L = I_1 z_{12} + I_2 z_{22}$$

$$\frac{I_2}{I_1} = \frac{-z_{21}}{z_{22} + Z_L}$$

$$Z_{in} = z_{11} - \frac{z_{12}z_{21}}{z_{22} + Z_L}$$

$$Z_{in} = \frac{E_1}{I_1}$$

$$E_1 = h_{11}I_1 + h_{12}E_2$$

$$\frac{E_1}{I_1} = h_{11} + \frac{E_2}{I_1} h_{12}$$

$$I_2 = -E_2 Y_L = I_1 h_{21} + E_2 h_{22}$$

$$\frac{E_2}{I_1} = \frac{-h_{21}}{h_{22} + Y_L}$$

$$Z_{in} = h_{11} - \frac{h_{12}h_{21}}{h_{22} + Y_L}$$

A similar derivation using the generalized k parameters gives

$$M_{in} = k_{11} - \frac{k_{12}k_{21}}{k_{22} + M_L}$$

Transducer (Power) Gain G_T .

$$G_T = \frac{\text{power delivered to the load}}{\text{power available from the source}} = \frac{P_o}{P_{av_s}}$$

Available (Power) Gain, G_A .

$$G_A = \frac{\text{power available at the output}}{\text{power available from the source}} = \frac{P_{av_o}}{P_{av_s}}$$

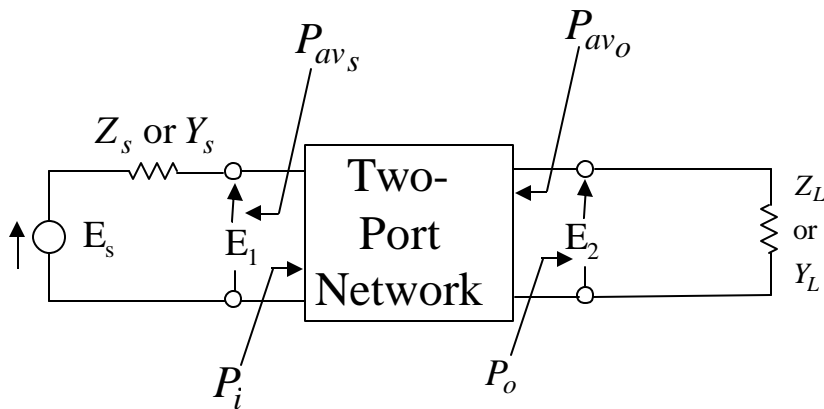

Power gains of a two port.

$$\text{Power gain} = G = \frac{P_o}{P_i}$$

$$\text{Transducer gain} = G_T = \frac{P_o}{P_{av_s}}$$

$$\text{Available gain} = G_A = \frac{P_{av_o}}{P_{av_s}}$$

Tabulation of Functions in Terms of General Parameters And Variables

Independent input variable	U_{ii}
Independent output variable	U_{oi}
Source Variable	U_s
Source immittance	M_s
Input immittance	M_{in}
Dependent input variable	U_{id}
Dependent output variable	U_{od}
Load variable	U_L
Load immittance	M_L
Output immittance	M_o

Defining equations:

$$U_{id} = U_{ii}k_{11} + U_{oi}k_{12}$$

$$U_{od} = U_{ii}k_{21} + U_{oi}k_{22}$$

Two-port parameters:

$$M_{in} = k_{11} - \frac{k_{12}k_{21}}{k_{22} + M_L} \qquad M_o = k_{22} - \frac{k_{12}k_{21}}{k_{11} + M_s}$$

Amplification 1

$$\frac{U_{od}}{U_s} = \frac{k_{21}M_L}{(k_{11} + M_s)(k_{22} + M_L) - k_{12}k_{21}} = \frac{k_{21}M_L}{D}$$

General Parameters (continues)

Amplification 2 :

$$\frac{U_{oi}}{U_s} = \frac{-k_{21}}{(k_{11} + M_s)(k_{22} + M_L) - k_{12}k_{21}} = \frac{-k_{21}}{D}$$

Power gains :

$$G = \frac{M_{Lr} |k_{21}|^2}{\text{Re}[k_{11} - k_{12}k_{21}/(k_{22} + M_L)] |k_{22} + M_L|^2}$$

$$G_A = \frac{|k_{21}|^2 M_{sr}}{\text{Re}[(k_{11}k_{22} - k_{12}k_{21} + k_{22}M_s)(k_{11} + M_s)]}$$

$$G_T = \frac{4|k_{21}|^2 M_{Lr} M_{sr}}{|(k_{11} + M_s)(k_{22} + M_L) - k_{12}k_{21}|^2}$$

Sensitivities of U_{oi}/U_s or U_{od}/U_s to changes in k 's :

$$S_{k11} = \frac{-k_{11}(k_{22} + M_L)}{D}$$

$$S_{k12} = \frac{k_{12}k_{21}}{D}$$

$$S_{k21} = \frac{(k_{11} + M_s)(k_{22} + M_L)}{D}$$

$$S_{k22} = \frac{-k_{22}(k_{11} + M_s)}{D}$$

Stability Conditions

For a two-port that is not potentially unstable the following inequalities must be satisfied:

$$i) \quad \frac{P_o}{P_{av_s}} = G_T \leq G = \frac{P_o}{P_1}$$

$$ii) \quad G_T = G_{max}$$

$$\frac{P_o}{P_{av_s}} = G_T \leq G_A = \frac{P_{av_o}}{P_{av_s}}$$

Transducer gain only equals the available gain when the output port is conjugate-matched. It can be proved that the condition for potential instability of the ports with real parameters is

$$h_{12}h_{21} \geq h_{11}h_{22}$$

Stability Summary of Results.

$\frac{P_{o0}}{P_{i0}}$ is within 3dB of the maximum available gain unless the port is potentially unstable at the frequency in question.

The port is potentially unstable if $\frac{P_{o0}}{P_{i0}}$ is negative or if the critical factor C exceed unity

$$C = \frac{2P_{o0}}{P_{i0}} \left| \frac{h_{12}}{h_{21}} \right|$$

When C is less than 1, the maximum available gain is

$$\frac{K_G P_{o0}}{P_{i0}} = \frac{P_{o0}}{P_{i0}} \frac{(1 - \sqrt{1 - C^2})}{C^2}$$

Where

$$\frac{P_{oO}}{P_{iO}} = \frac{|h_{21}|^2}{4h_{11r}h_{22r} - 2\text{Re}(h_{12}h_{21})}$$

$$\mathbf{q} = \arg(-h_{12}h_{21})^* = -\arg(-h_{12}h_{21})$$

$$Z_{s,opt} = Z_{in}^* = \left[h_{11} - \frac{h_{12}h_{21}}{2h_{22r}} \left(1 - \frac{CK_G \exp j\mathbf{q}}{2} \right) \right]^*$$

$$Y_{L,opt} = Y_o^* = -h_{22} + \frac{2h_{22r}}{1 - CK_G \exp j\mathbf{q} / 2}$$

Scattering Parameters.

For very high-frequencies where short- or open-circuit conditions are not possible, an alternative method of representing a linear time-invariant network is by means of its scattering parameters, also known as S-Parameters.

One-Port Example

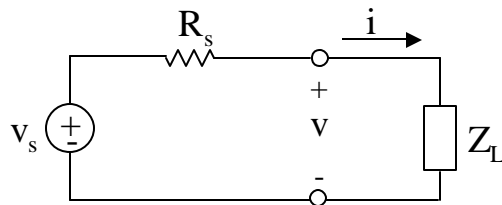

Transmission line with Z_o characteristic impedance.

Incident voltage v_i

Reflected voltage v_r

$$v = v_i + v_r$$

$$i = i_i - i_r$$

$$i = \frac{1}{Z_o}(v_i - v_r)$$

Thus

$$v_r = \frac{1}{2}(v - Z_o i)$$

$$v_i = \frac{1}{2}(v + Z_o i)$$

The reflection coefficient is defined as :

$$\rho = \frac{v_r}{v_i} = \frac{v - Z_o i}{v + Z_o i}$$

Instant power $p(t)$ is given by

$$p(t) = v(t) i(t) = \frac{1}{Z_o} (v_i + v_r)(v_i - v_r) = \frac{1}{Z_o} (v_i^2 - v_r^2)$$

maximizing $p(t)$ implies minimizing v_r and ρ

The scattering parameter of the one - port is defined as :

$$S = \frac{v_r}{v_i} = \frac{i_r}{i_i} = \frac{v - R_i}{v + R_i}$$

for the (lumped) case of Z_o becoming equal to R . Furthermore, the open circuit impedance is related as

$$v = Z_{oc} i \text{ or } i = y_{sc} v$$

$$S = \frac{Z_{oc} - R}{Z_{oc} + R} = \frac{1 - Ry_{sc}}{1 + Ry_{sc}}$$

Example

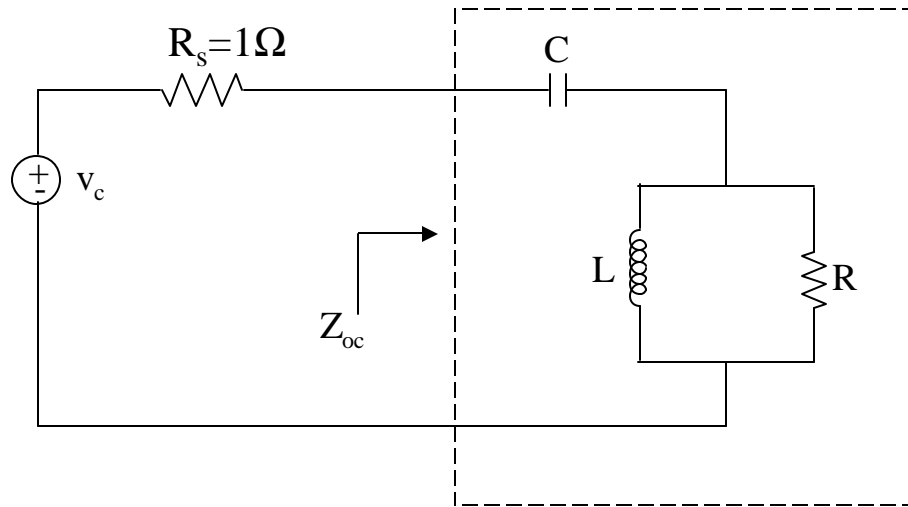

$$Z_{oc} = \frac{1}{sC} + \frac{1}{\frac{1}{R} + \frac{1}{sL}}$$

$$Z_{oc} = \frac{s^2 RLC + sL + R}{s^2 LC + sRC}$$

$$S = \frac{Z_{oc} - R_s}{Z_{oc} + R_s} = \frac{s^2 LC(R - R_s) + s(L - RR_s C) + R}{s^2 LC(R + R_s) + s(L + RR_s C) + R}$$

Let us consider a two-port network

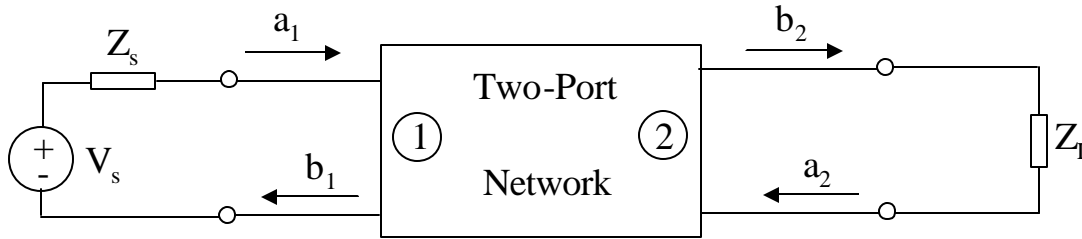

$$a_1 = V_{i1} / \sqrt{Z_o}$$

$$b_1 = V_{r1} / \sqrt{Z_o}$$

$$a_2 = V_{i2} / \sqrt{Z_o}$$

$$b_2 = V_{r23} / \sqrt{Z_o}$$

$$\begin{bmatrix} b_1 \\ b_2 \end{bmatrix} = \begin{bmatrix} S_{11} & S_{12} \\ S_{21} & S_{22} \end{bmatrix} \begin{bmatrix} a_1 \\ a_2 \end{bmatrix}$$

i.e.,

$$b_2 = S_{21}a_1 + S_{22}a_2$$

$$S_{21} \equiv \left. \frac{b_2}{a_1} \right|_{a_2=0} \quad ; \quad S_{22} = \left. \frac{b_2}{a_2} \right|_{a_1=0}$$

$$\text{If } Z_L = Z_o \text{ , } a_2 = 0$$

- b_1 , b_2 , a_1 , a_2 have the dimensions of power. Next signal flow graph representations are introduced.

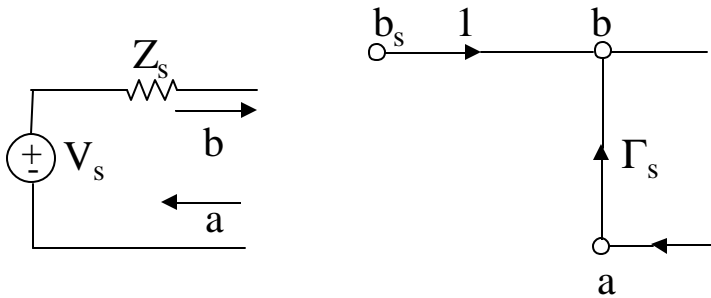

$$P_{avs} = \frac{|b_s|^2}{1 - |\mathbf{G}_s|^2} = |b|^2 - |a|^2$$

$$b_s = \frac{V_s \sqrt{Z_o}}{Z_s + Z_o}$$

$$b_s = \frac{V_s}{Z_s / \sqrt{Z_o} + \sqrt{Z_o}}$$

A two-port with a source and a load.

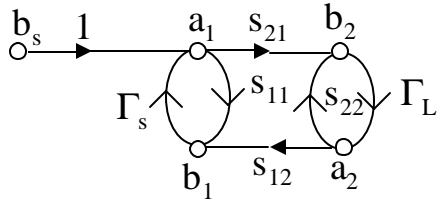

Using Mason's Rule

$$\frac{b_1}{b_s} = \frac{S_{11}(1 - S_{22}\mathbf{G}_L) + S_{21}\mathbf{G}_L S_{12}}{1 - (S_{11}\mathbf{G}_s + S_{22}\mathbf{G}_L + S_{21}\mathbf{G}_L S_{12}\mathbf{G}_s) + S_{11}\mathbf{G}_s S_{22}\mathbf{G}_L}$$

$$G_T = \frac{P_{del}}{P_{avs}} = \frac{|b_2|^2 (1 - |\mathbf{G}_L|^2)}{|b_s|^2 / (1 - |\mathbf{G}_s|^2)}$$

$$\frac{b_2}{b_s} = \frac{S_{21}}{1 - (S_{11}\mathbf{G}_s + S_{22}\mathbf{G}_L + S_{21}\mathbf{G}_L S_{12}\mathbf{G}_s) + S_{11}\mathbf{G}_s S_{22}\mathbf{G}_L}$$

$$G_T = \frac{|S_{21}|^2 (1 - |\Gamma_s|^2) (1 - |\Gamma_L|^2)}{|(1 - S_{11}\Gamma_s)(1 - S_{22}\Gamma_L) - S_{21}S_{12}\Gamma_L\Gamma_s|^2}$$

For ideal amplifiers $S_{12} = 0$, then

$$G_T \cong \frac{|S_{21}|^2 (1 - |\Gamma_s|^2) (1 - |\Gamma_L|^2)}{|(1 - S_{11}\Gamma_s)(1 - S_{22}\Gamma_L)|^2}$$

Also the total voltage gain is given by

$$A_V = \frac{a_2 + b_2}{a_1 + b_1} = \frac{\frac{a_2}{b_s} + \frac{b_2}{b_s}}{\frac{a_1}{b_s} + \frac{b_1}{b_s}}$$

$$A_V = \frac{S_{21}\Gamma_L + S_{21}}{(1 - S_{22}\Gamma_L) + S_{11}(1 - S_{22}\Gamma_L) + S_{21}S_{12}\Gamma_L}$$

Stability Considerations using S-Parameters

- Max G_T occurs when $\mathbf{G}_s = \mathbf{G}_{in}^*$ and $\mathbf{G}_L = \mathbf{G}_{out}^*$
- **Conditionally Stable** if $\text{Re}\{Z_{in}\}$ and $\text{Re}\{Z_{out}\} > 0$ for some specific positive real load and source impedance at a specific frequency. If this condition is satisfied for all positive real load and source impedances then the network is **Unconditionally Stable**. $|\mathbf{G}_s| \leq 1$, $|\mathbf{G}_L| \leq 1$
- For conjugately match the input and output, the network will be stable if $K > 1$

$$K = \frac{1 + |S_{11}S_{22} - S_{12}S_{21}|^2 - |S_{11}|^2 - |S_{22}|^2}{2|S_{12}||S_{21}|}$$

REFLECTION COEFFICIENTS

$$\Gamma_{IN} = \frac{b_1}{a_1} = S_{11} + \frac{S_{21}S_{12}\Gamma_L}{1 - S_{22}\Gamma_L}$$

$$\Gamma_{out} = \frac{b_2}{a_2} = S_{22} + \frac{S_{21}S_{12}\Gamma_s}{1 - S_{11}\Gamma_s}$$

If one sets $|\Gamma_{in}| = 1$, the solutions of Γ_L lie on a circle. The radius, and center are given by

$$radius = r_L = \left| \frac{S_{12}S_{21}}{|S_{22}|^2 - |\Delta|^2} \right|$$

$$\Delta = S_{11}S_{22} - S_{12}S_{21}$$

$$center = C_L = \frac{(S_{22} - \Delta S_{11})^*}{|S_{22}|^2 - |\Delta|^2}$$

This circle can be plotted on a Smith Chart to determine all values of Γ_L that make $|\Gamma_{in}| = 1$.